

Next Vision Display

Brighten The Future

SPECIFICATION

CUSTOMER : _____

MODULE NO.: NV320240F350#W027

Web: www.nextvisiondisplay.com

Info: technical@nextvisiondisplay.com

Contents

- 1.Records of Revision
- 2.Summary
- 3.General Specification
- 4.Absolute Maximum Ratings
- 5.Electrical Characteristics
- 6.AC Characteristics
- 7.Optical Characteristics
- 8.Interface
- 9.Block Diagram
- 10.Reliability
- 11.Contour Drawing
- 12.Package Specification
- 13.Other

1. Records of Revision

			MODLE NO :
RECORDS OF REVISION			DOC. FIRST ISSUE
VERSION	 DATE	REVISED PAGE NO.	SUMMARY
0	2014/04/18		First issue
A	2015/04/27		Add size & Surface. Modify LED Life Time , Brightness ,Reliability & Block Diagram.

2.Summary

This technical specification applies to 3.45' color TFT-LCD panel. The 3.45' color TFT-LCD panel is designed for camcorder, digital camera application and other electronic products which require high quality flat panel displays. This module follows RoHS.

3. General Specifications

Item	Dimension	Unit
Size	3.5	inch
Dot Matrix	320 x RGBx240(TFT)	dots
Module dimension	76.9x 63.9x 3.27	mm
Active area	70.08 x 52.56	mm
Dot pitch	0.073 x 0.219	mm
LCD type	TFT, Normally White, Transmissive	
View Direction	12o'clock	
Gray Scale Inversion Direction	6 o'clock	
Backlight Type	LED ,Normally White	
With /Without TP	Without TP	
Surface	Anti-Glare	

*Color tone slight changed by temperature and driving voltage.

4. Absolute Maximum Ratings

Item	Symbol	Min	Typ	Max	Unit
Operating Temperature	TOP	-20	—	+70	°C
Storage Temperature	TST	-30	—	+80	°C

Note: Device is subject to be damaged permanently if stresses beyond those absolute maximum ratings listed above

1. Temp. $\leq 60^{\circ}\text{C}$, 85% RH MAX. Temp. $> 60^{\circ}\text{C}$, Absolute humidity shall be less than 85% RH at 60°C

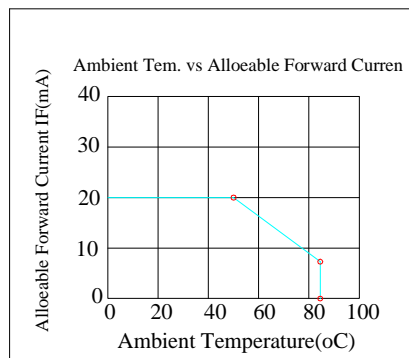

5. Electrical Characteristics

5.1. Operating conditions:

Item	Symbol	Condition	Min	Typ	Max	Unit	Remark
Supply Voltage For LCM	VCC	—	3.0	3.3	3.6	V	
Supply Current For LCM	ICC	—	—	4	10	mA	Note 1

Note 1 : This value is test for VDD=3.3V , Ta=25 °C only

5.2. LED driving conditions

Parameter	Symbol	Min.	Typ.	Max.	Unit	Remark
LED current		18	20	25	mA	
LED voltage	LED+	18.0	19.8	21	V	Note 1
LED Life Time		20,000	-	-	Hr	Note 2,3,4

Note 1 : There are 1 Groups LED

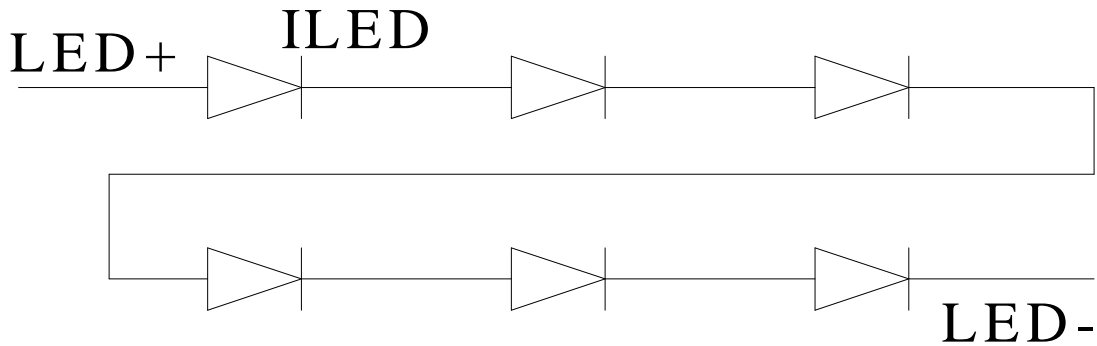

Note 2 : Ta = 25 °C

Note 3 : Brightness to be decreased to 50% of the initial value

Note 4 : The single LED lamp case

6.Data input Characteristics

Parallel RGB Interface

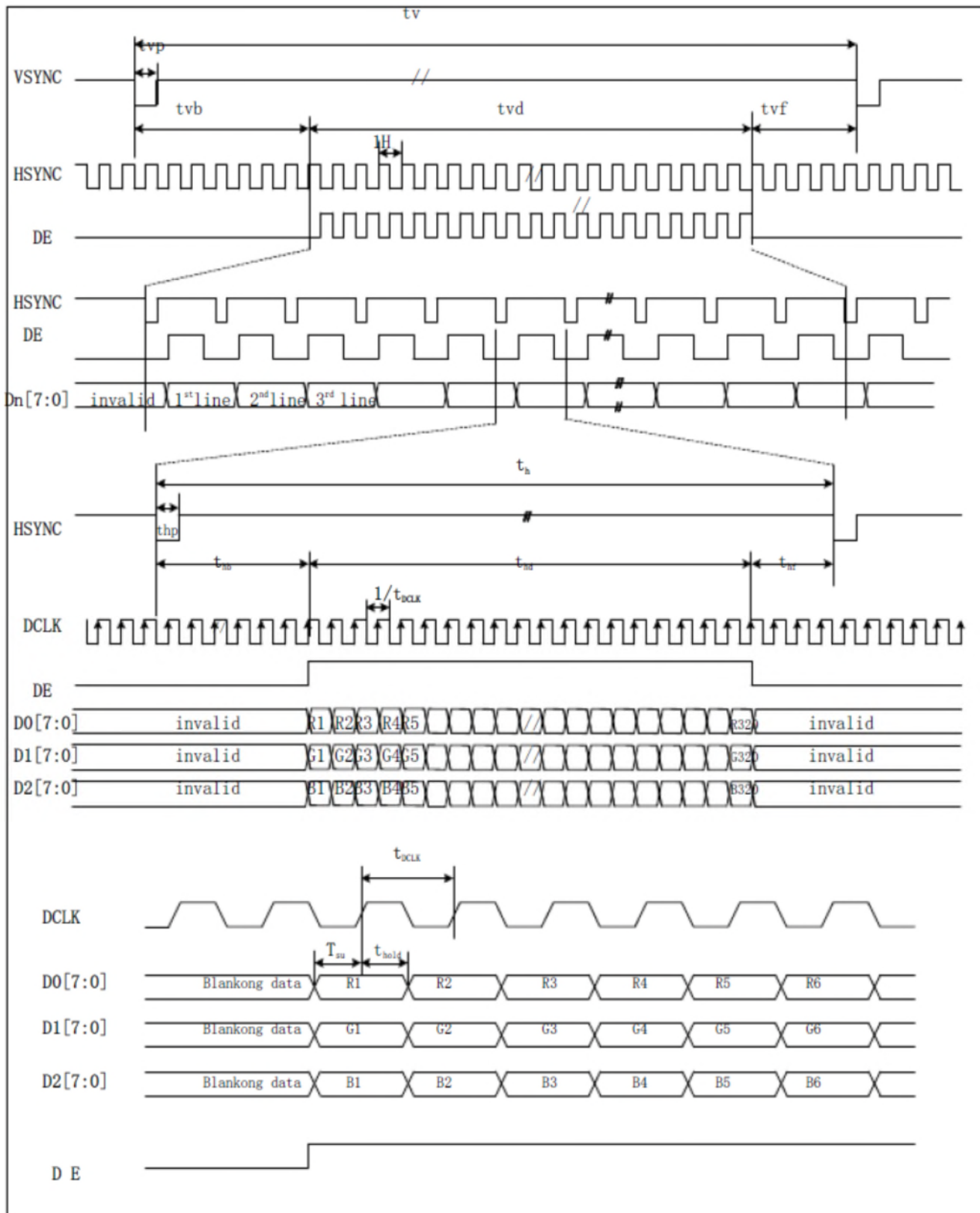

Parallel RGB Input Signal Timing

Parameter	Symbol	Min.	Typ	Max.	Unit.	Note
DCLK Frequency	1/ tDCLK	—	6.5	10	MHz	
Horizontal Period	th	—	408	—	tDCLK	
Horizontal Display	thd	320	320	320	tDCLK	
Horizontal Back Porch	thb	—	68	—	tDCLK	
Horizontal Front Porch	thf	—	20	—	tDCLK	
Horizontal Pulse Width	thp	1	—	—	tDCLK	
Vertical Period	tv	—		—	th	
Vertical Display Period	tvd	240	240	240	th	
Vertical Back Porch	tvb	—	18	—	th	
Vertical Front Porch	tvf	—	4	—	th	
Vertical Pulse Width	tvp	1	—	—	th	
Data setup time	tsu	12	—	—	ns	
Data hold time	thold	12	—	—	ns	

7. Optical Characteristics

Item	Symbol	Condition.	Min	Typ.	Max.	Unit	Remark	
Response time	Tr+ Tf	$\theta = 0^\circ \cdot \Phi = 0^\circ$	-	25	40	ms	Note 3,5	
Contrast ratio	CR	At optimized viewing angle	300	350	-	-	Note 4,5	
Color Chromaticity	White	$\theta = 0^\circ \cdot \Phi = 0$	Wx	0.285	0.305	0.325	-	Note 2,6,7
	Wy		0.314	0.334	0.354	-	-	
Viewing angle (Gray Scale Inversion Direction)	Hor.	CR ≥ 10	Θ_R	60	70	-	Deg.	Note 1
			Θ_L	60	70	-		
	Ver.		Φ_T	40	50	-		
			Φ_B	60	70	-		
Brightness	-	-	350	400	-	Cd/m ²	Center of display	

Ta=25±2°C, IL=20mA

Note 1: Definition of viewing angle range

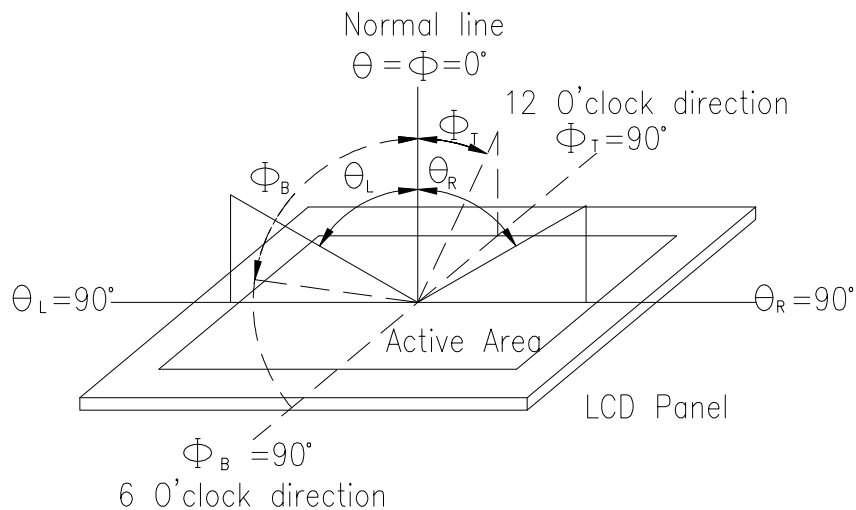

Fig. 7.1. Definition of viewing angle

Note 2: Test equipment setup:

After stabilizing and leaving the panel alone at a driven temperature for 10 minutes, the measurement should be executed. Measurement should be executed in a stable, windless, and dark room. Optical

specifications are measured by Topcon BM-7 or BM-5 luminance meter 1.0° field of view at a distance of 50cm and normal direction.

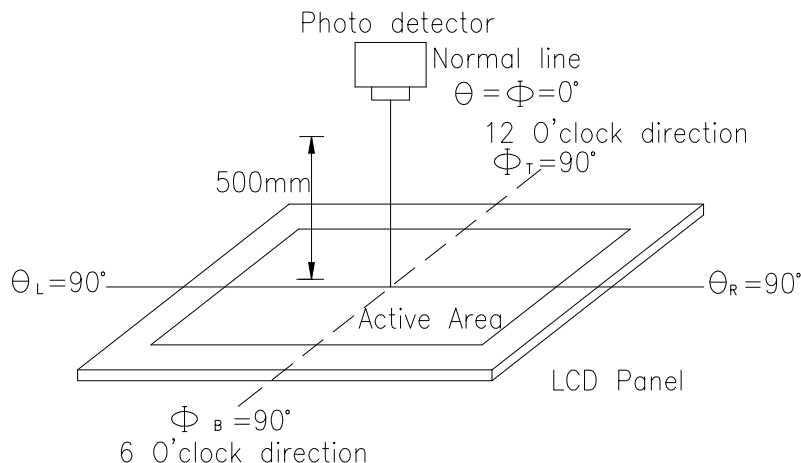
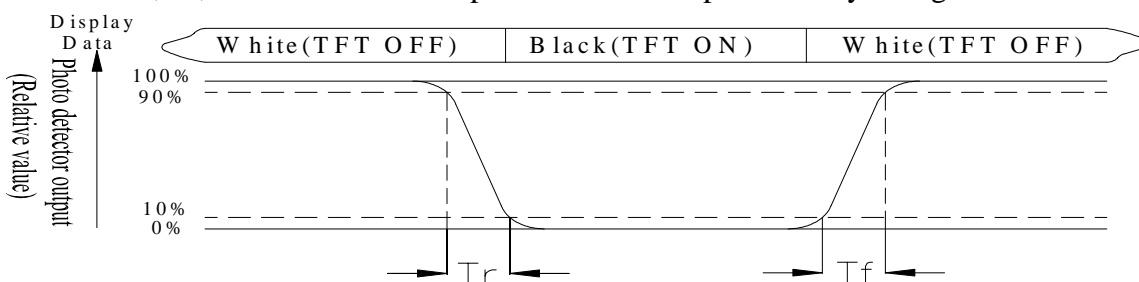

Fig. 7.2. Optical measurement system setup

Note 3: Definition of Response time:

The response time is defined as the LCD optical switching time interval between “White” state and “Black” state. Rise time, T_r , is the time between photo detector output intensity changed from 90% to 10%. And fall time, T_f , is the time between photo detector output intensity changed from 10% to 90%



Note 4: Definition of contrast ratio:

The contrast ratio is defined as the following expression.

$$\text{Contrast ratio (CR)} = \frac{\text{Luminance measured when LCD on the "White" state}}{\text{Luminance measured when LCD on the "Black" state}}$$

Note 5: White $V_i = V_{i50} \pm 1.5V$

Black $V_i = V_{i50} \pm 2.0V$

“±” means that the analog input signal swings in phase with VCOM signal.

“±” means that the analog input signal swings out of phase with VCOM signal.

The 100% transmission is defined as the transmission of LCD panel when all the input terminals of module are electrically opened.

Note 6: Definition of color chromaticity (CIE 1931)

Color coordinates measured at the center point of LCD

Note 7: Measured at the center area of the panel when all the input terminals of LCD panel are electrically opened.

8.Interface

8.1. LCM PIN Definition

Pin	Symbol	Function	Remark
1	LED-	Power for LED backlight cathode	
2	LED-	Power for LED backlight cathode	
3	LED+	Power for LED backlight anode	
4	LED+	Power for LED backlight anode	
5	NC	No connect	
6	NC	No connect	
7	NC	No connect	
8	/RESET	Hardware reset	
9	CS	Chip select pin of serial interface	
10	SPCLK	Clock pin of serial interface	
11	SPDAT	Data input pin in serial mode	
12	B0	Data bus	
13	B1	Data bus	
14	B2	Data bus	
15	B3	Data bus	
16	B4	Data bus	
17	B5	Data bus	
18	B6	Data bus	
19	B7	Data bus	
20	G0	Data bus	
21	G1	Data bus	
22	G2	Data bus	
23	G3	Data bus	
24	G4	Data bus	
25	G5	Data bus	
26	G6	Data bus	
27	G7	Data bus	
28	R0	Data bus	
29	R1	Data bus	
30	R2	Data bus	
31	R3	Data bus	
32	R4	Data bus	
33	R5	Data bus	
34	R6	Data bus	
35	R7	Data bus	
36	HSYNC	Line synchronization signal	
37	VSYNC	Frame synchronization signal	
38	DCLK	Dot-clock signal and oscillator source	
39	NC	No connect	
40	NC	No connect	
41	VCC	Power Supply	
42	VCC	Power Supply	
43	NC	No connect	
44	NC	No connect	

45	NC	No connect	
46	NC	No connect	
47	NC	No connect	
48	NC	No connect	
49	NC	No connect	
50	NC	No connect	
51	NC	No connect	
52	DE	Display enable pin from controller. Internal pull high Connect to VDDIO or floating if not used	
53	DGND	System ground pin of the IC. Connect to system ground.	
54	AVSS	Grounding for analog circuit. Connect to system ground	

8.2. Serial Peripheral Interface(SPI)

The SPI is available through the chip select line (CSB), serial transfer clock line (SCK), serial data input (SDI), and serial data output (SDO).

The Driver IC recognizes the start of data transfer at the falling edge of CSB input to initiate the transfer of start byte. It recognizes the end of data transfer at the rising edge of CSB input. The Driver IC is selected when the 6-bit chip address in the start byte transferred from the transmission device and the 6-bit device identification code assigned to the Driver IC are compared and both 6-bit data correspond. The identification code must be 011100(Primary SPI Register) or 011101(Secondary SPI Register). Two different chip addresses must be assigned to the Driver IC because the seventh bit of the start byte is assigned to a register select bit (RS). When RS = 0, index register write or status read is executed. When the RS=1, instruction write. The eighth bit of the start byte is to specify read or write (R/W bit). The data are received when the R/W bit is 0, and are transmitted when the R/W bit is 1. After receiving the start byte, the Driver IC starts to transmit or receive data by byte. The data transmission adopts a format by which the MSB is first transmitted (9th SCK started). All Driver IC instructions consist of 16 bits and they are executed internally after two bytes are transmitted with the MSB first (IB15 to 0---9th ~24th SCK).

Figure 6 SPI Interface Input Signal Timing

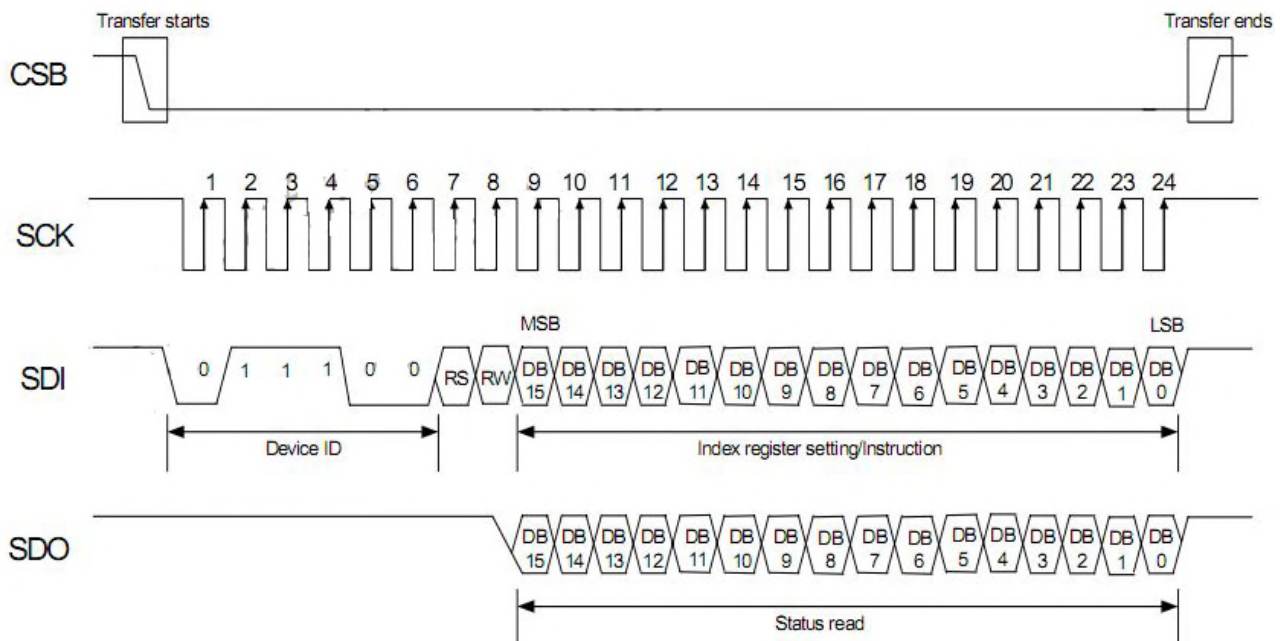

8.3. Recommend Register Setting

(Reference HX8238-D specification)

```
SPIByteWrite_reg(0x0001);  
SPIByteWrite_data(0x6300); //Line Inversion
```

```
SPIByteWrite_reg(0x0002);  
SPIByteWrite_data(0x0200);
```

```
SPIByteWrite_reg(0x0003);  
SPIByteWrite_data(0x8286);
```

```
SPIByteWrite_reg(0x0004);  
SPIByteWrite_data(0x04c7);
```

```
SPIByteWrite_reg(0x0005);  
SPIByteWrite_data(0xA800);
```

```
SPIByteWrite_reg(0x0008);  
SPIByteWrite_data(0x06ff);
```

```
SPIByteWrite_reg(0x000a);  
SPIByteWrite_data(0x4008);
```

```
SPIByteWrite_reg(0x000b);  
SPIByteWrite_data(0xd400);
```

```
SPIByteWrite_reg(0x000d);  
SPIByteWrite_data(0x3229);
```

```
SPIByteWrite_reg(0x000e);  
SPIByteWrite_data(0x1200);
```

```
SPIByteWrite_reg(0x000f);  
SPIByteWrite_data(0x0000);
```

```
SPIByteWrite_reg(0x0016);  
SPIByteWrite_data(0x9f80);
```

```
SPIByteWrite_reg(0x0017);  
SPIByteWrite_data(0x2212);
```

```
SPIByteWrite_reg(0x001e);  
SPIByteWrite_data(0x00fc);
```

```
SPIByteWrite_reg(0x0030);  
SPIByteWrite_data(0x0000);  
SPIByteWrite_reg(0x0031);  
SPIByteWrite_data(0x0707);  
SPIByteWrite_reg(0x0032);  
SPIByteWrite_data(0x0206);
```

SPIByteWrite_reg(0x0033);
SPIByteWrite_data(0x0001);

SPIByteWrite_reg(0x0034);
SPIByteWrite_data(0x0105);
SPIByteWrite_reg(0x0035);
SPIByteWrite_data(0x0000);
SPIByteWrite_reg(0x0036);
SPIByteWrite_data(0x0707);

SPIByteWrite_reg(0x0037);
SPIByteWrite_data(0x0100);

SPIByteWrite_reg(0x003a);
SPIByteWrite_data(0x0502);
SPIByteWrite_reg(0x003b);
SPIByteWrite_data(0x0502);

9. Block Diagram

LCD Panel

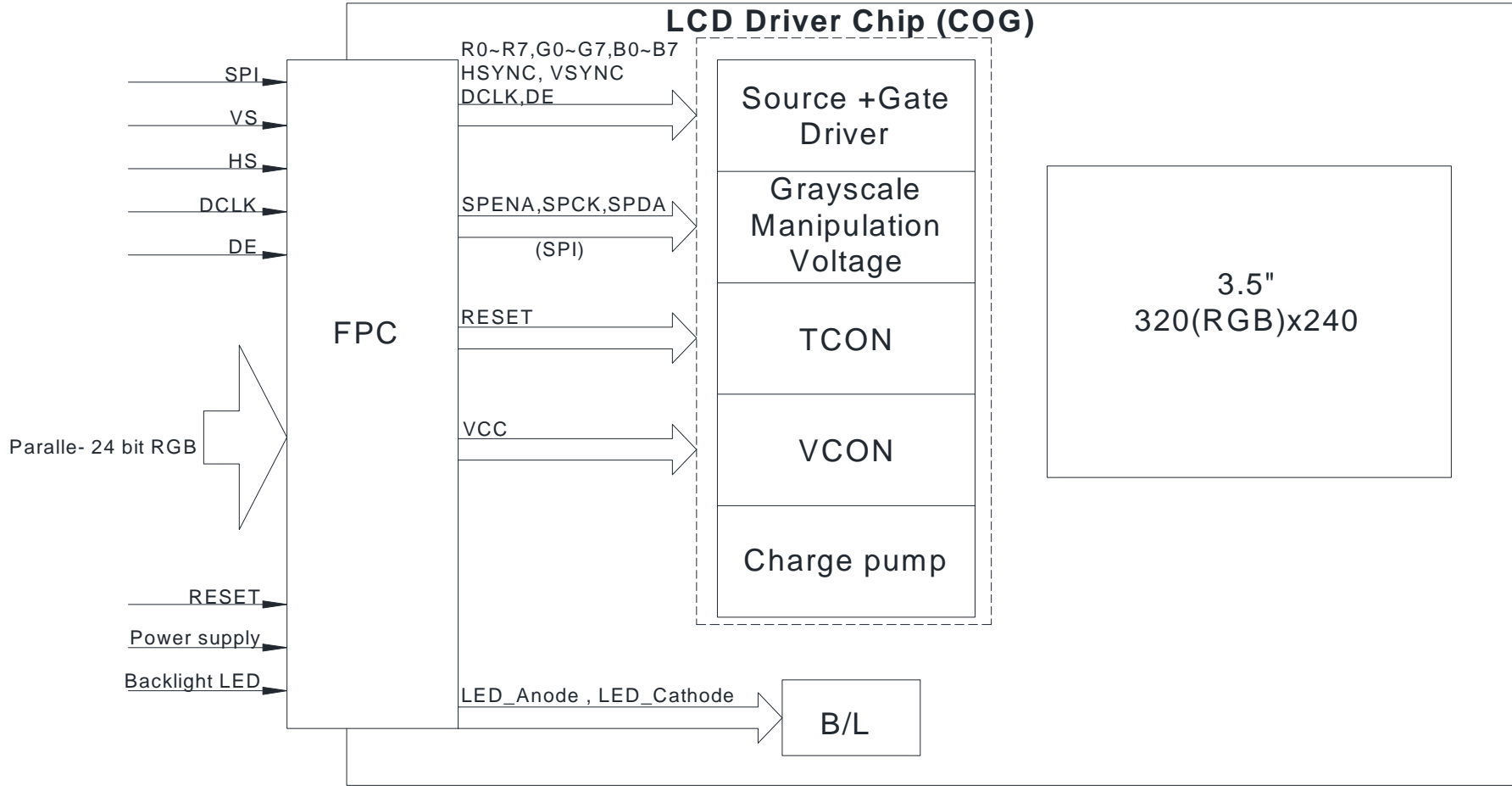

10. Reliability

Content of Reliability Test (Wide temperature, -20°C ~70°C)

Environmental Test			
Test Item	Content of Test	Test Condition	Note
High Temperature storage	Endurance test applying the high storage temperature for a long time.	80°C 96hrs	2
Low Temperature storage	Endurance test applying the low storage temperature for a long time.	-30°C 96hrs	1,2
High Temperature Operation	Endurance test applying the electric stress (Voltage & Current) and the thermal stress to the element for a long time.	70°C 96hrs	—
Low Temperature Operation	Endurance test applying the electric stress under low temperature for a long time.	-20°C 96hrs	1
High Temperature/ Humidity Operation	The module should be allowed to stand at 60 °C ,85%RH max	60°C ,85%RH 96hrs	1,2
Thermal shock resistance	The sample should be allowed stand the following 10 cycles of operation <div style="text-align: center;"> <p style="margin: 0;">-20°C 25°C 60°C</p> <p style="margin: 0;">30min 5min 30min</p> <p style="margin: 0;">1 cycle</p> </div>	-20°C/60°C 10 cycles	—
Vibration test	Endurance test applying the vibration during transportation and using.	Total fixed amplitude : 15mm Vibration Frequency : 10~55Hz One cycle 60 seconds to 3 directions of X,Y,Z for Each 15 minutes	3
Static electricity test	Endurance test applying the electric stress to the terminal.	VS=800V, RS=1.5kΩ CS=100pF 1 time	—

Note1: No dew condensation to be observed.

Note2: The function test shall be conducted after 4 hours storage at the normal Temperature and humidity after remove from the test chamber.

Note3: The packing have to including into the vibration testing.

11. Contour Drawing

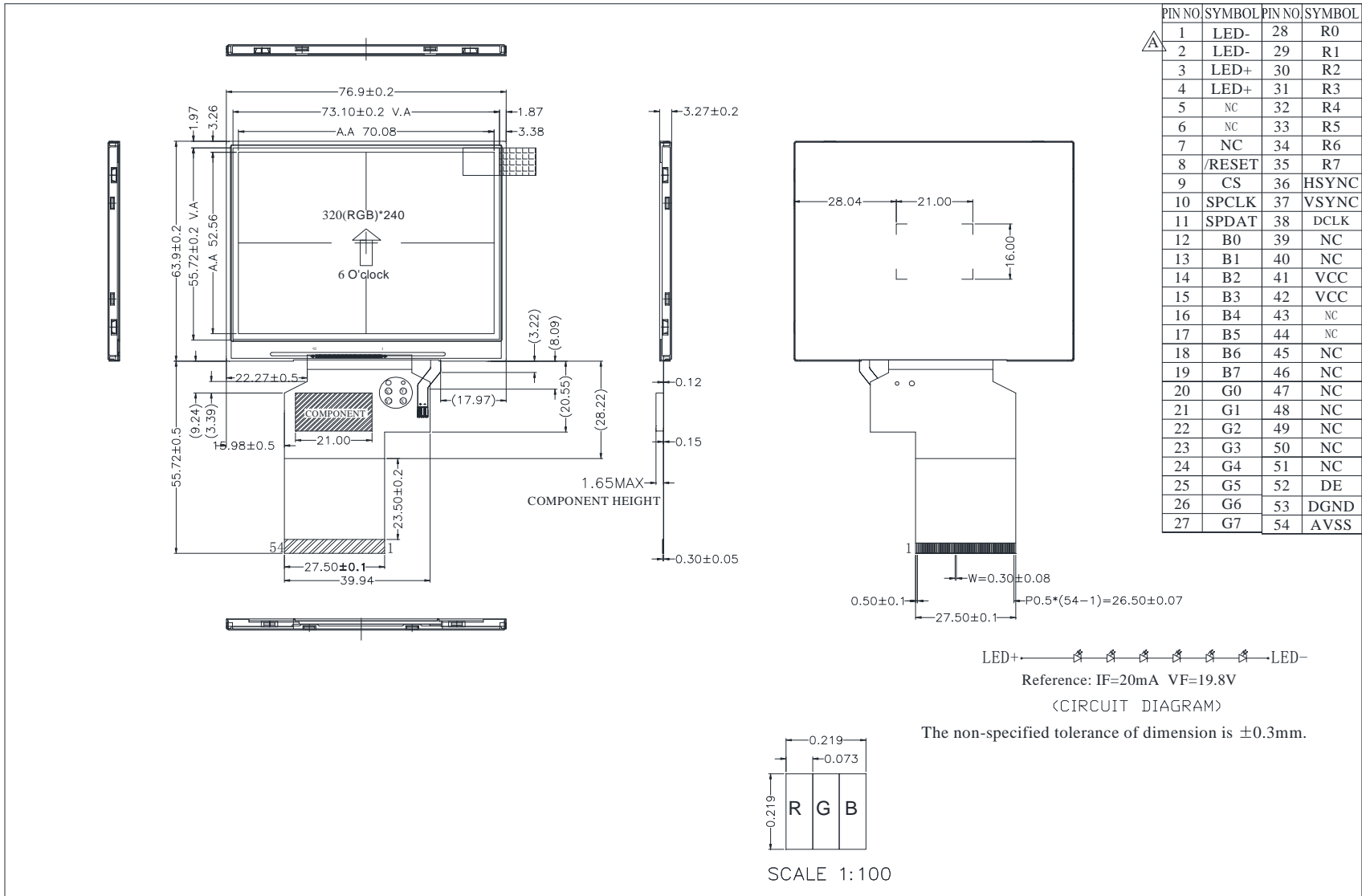

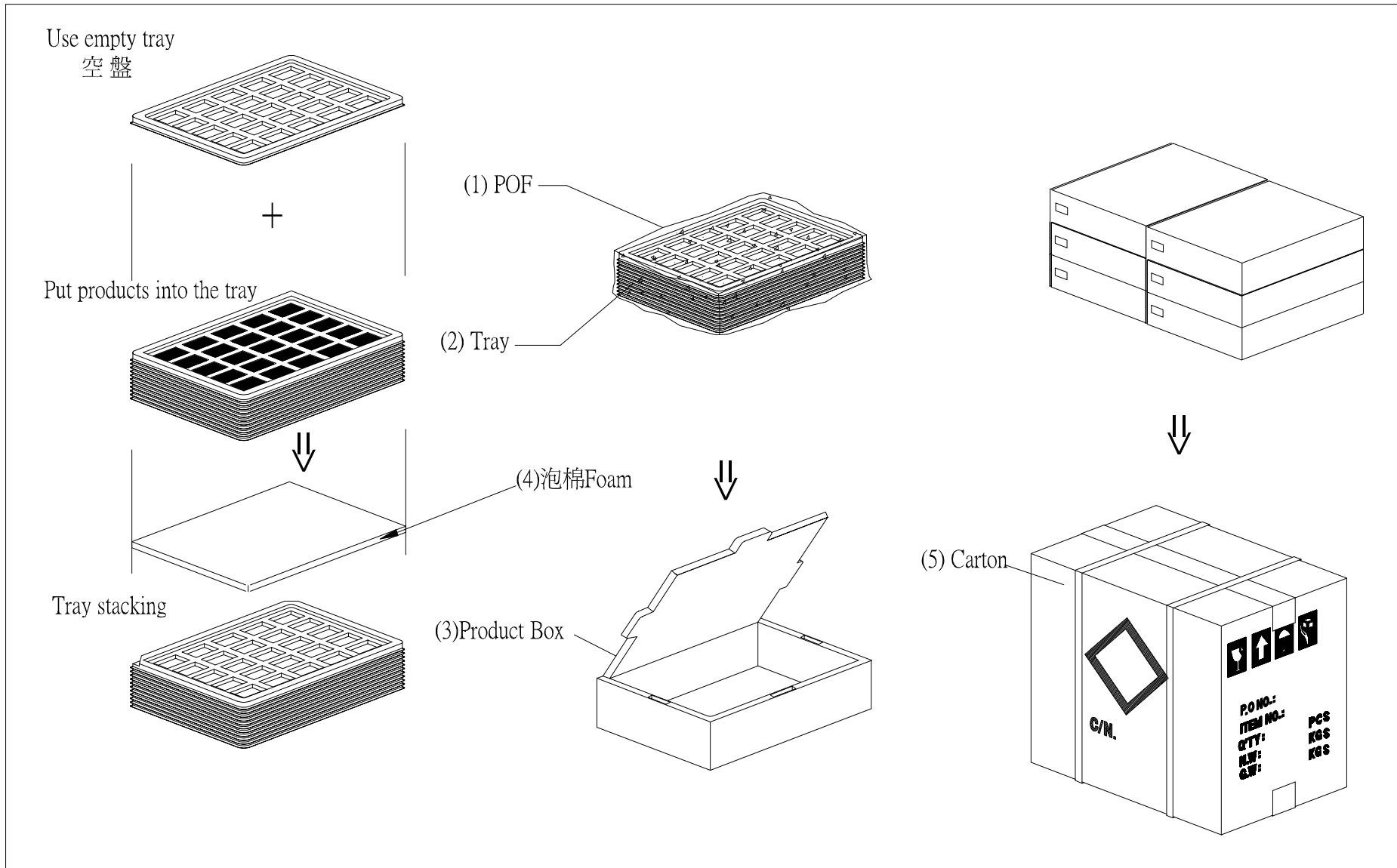

LCM Sample Estimate Feedback Sheet

Module Number : _____

Page: 1

1、Panel Specification :

1. Panel Type : Pass NG , _____
2. View Direction : Pass NG , _____
3. Numbers of Dots : Pass NG , _____
4. View Area : Pass NG , _____
5. Active Area : Pass NG , _____
6. Operating Temperature : Pass NG , _____
7. Storage Temperature : Pass NG , _____
8. Others : _____

2、Mechanical

1. PCB Size : Pass NG , _____
2. Frame Size : Pass NG , _____
3. Material of Frame : Pass NG , _____
4. Connector Position : Pass NG , _____
5. Fix Hole Position : Pass NG , _____
6. Backlight Position : Pass NG , _____
7. Thickness of PCB : Pass NG , _____
8. Height of Frame to PCB : Pass NG , _____
9. Height of Module : Pass NG , _____
10. Others : Pass NG , _____

3、Relative Hole Size :

1. Pitch of Connector : Pass NG , _____
2. Hole size of Connector : Pass NG , _____
3. Mounting Hole size : Pass NG , _____
4. Mounting Hole Type : Pass NG , _____
5. Others : Pass NG , _____

4、Backlight Specification :

1. B/L Type : Pass NG , _____
2. B/L Color : Pass NG , _____
3. B/L Driving Voltage (Reference for LED) : Pass NG , _____
4. B/L Driving Current : Pass NG , _____
5. Brightness of B/L : Pass NG , _____
6. B/L Solder Method : Pass NG , _____
7. Others : Pass NG , _____

>> **Go to page 2** <<

5、Electronic Characteristics of Module :

- 1. Input Voltage : Pass NG , _____
- 2. Supply Current : Pass NG , _____
- 3. Driving Voltage for LCD : Pass NG , _____
- 4. Contrast for LCD : Pass NG , _____
- 5. B/L Driving Method : Pass NG , _____
- 6. Negative Voltage Output : Pass NG , _____
- 7. Interface Function : Pass NG , _____
- 8. LCD Uniformity : Pass NG , _____
- 9. ESD test : Pass NG , _____
- 10. Others : Pass NG , _____

6、Summary :

Sales signature : _____

Customer Signature : _____

Date : / / _____